

## - Power Supplies with DC Input - AC is not the Only Required Input Voltage

A device requiring a DC input and supplying a DC output voltage is most often referred to as a DC/DC converter. What most individuals do not know is that there are many AC/DC switch-mode power supplies that will accept a DC input. These types of power supplies can also be considered a DC/DC converter, but most converters only operate with a DC input and will be damaged if an AC voltage is applied. This article will primarily focus on power supplies operating with a DC input. For more information on DC/DC converters, please check out issue 7 of "The PULS Advantage" which addresses this topic.

### DC Wiring:

A DC voltage is allowed because most power supplies are designed to work on the primary side with direct current so using DC in lieu of AC on the input terminals is possible. Many power supplies have internal fuses as part of the design. However, the internal fuses are not suitable when DC is used instead of AC. Therefore, DC rated fuses should be utilized to properly protect the power supply. When connecting DC to a PULS

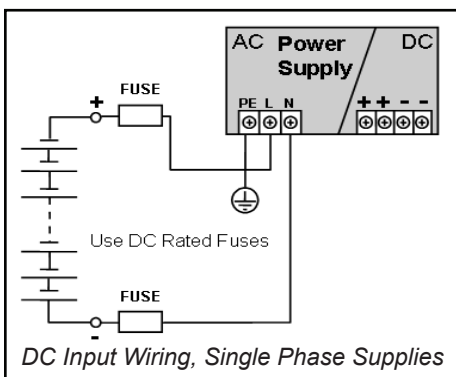

single phase power supply, the general rule is to connect the positive (+) voltage to the "L" terminal and the negative voltage (- or common) to the "N" terminal. If a supply has a manual select for input voltage, make sure the switch is in the 240V position. Many of the PULS 3-phase supplies will also accept a DC input, but

the input range is much higher than that of the single phase units. If using a 3-phase unit, the positive (+) voltage as a general rule should go to the "L1" terminal and the negative (- or common) voltage should be wired to the "L2" terminal. The "L3" terminal is left unused. With both single and 3-phase supplies, the PE (protected earth) terminal on the unit should be connected to the machine

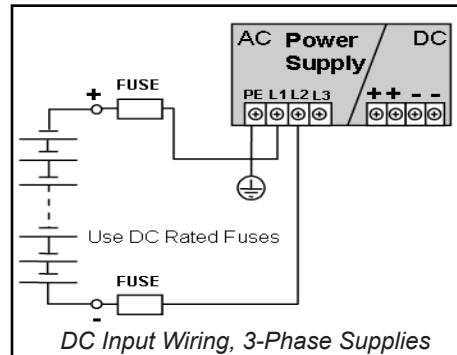

ground. If the minus (-) pole of the DC source is not grounded, an appropriate DC rated fuse should be used to protect the "N" or "L2" terminals on the supply. The voltage should be provided from a battery or other similar DC source and a standard supply should not be connected directly to the intermediate bus of a drive system. A higher DC voltage can be just as dangerous as AC, so caution should be used when dealing with live terminals.

### DC Range:

The PULS single phase supplies, depending on the model, can offer two different DC input ranges. The first range will operate as low as 88VDC and the upper range is 375VDC including tolerances. Other supplies fall into the range of approximately 200 - 375VDC also including the tolerances. The PULS 3-phase supplies that can accept DC operate on a range of approximately 450 - 780VDC with the tolerances included. Some of the PULS supplies are not designed to operate with a DC input, so please check the specific product data sheet to see if DC is allowed and in what operating range.

### Allowed Usage vs. UL Approved:

Although many manufacturer's data sheets including PULS indicate that a DC voltage is allowed on the input, most supplies are not UL approved for DC usage and additional testing may be required to meet certain standards. PULS single phase Q-Series power supplies are UL60950 approved for a DC operating range of 110 - 300VDC with a tolerance of -20%, +25%. These values can be found on the units rating label. This can be very beneficial when UL is required on specific applications.

### Applications:

There are too many applications that use a DC input to discuss in this article. However, it is very common in factories to have a back-up bus system operating at 125VDC. This voltage is critical when the main AC power fails. Using standard PULS power supplies, it is easy to build a redundant power supply system - one running on AC and another operating off the 125VDC bus, isolated from each other with a redundancy (diode) module. Utilities also have DC back-up systems in place and there are overhead crane systems that can use higher DC input voltages. Many consider PULS as the leader when it comes to delivering DC. But PULS can also handle your applications requiring DC input making us the true DC experts!

